

---

**DATA SHEET. Model: C-34Q.**

---

Individual charger for torches of the HS Series.



---

**Description**

---

Individual charger to optimally charge any of the Series HS model torches.  
Fast charging by means of three leads that provide steadily current without electrical hazard.  
Durable design that guarantees a strong fastening of the torch in accordance with the aesthetics.  
Mounting of the charger on any surface through a metallic fixation plate with four screws.  
Possibility of adaptation to 12 V DC power supply.

---

**Technical Characteristics**

---

Power supply	230 VAC. – 50 Hz
	12 VDC.
Plug type	European (C, E, F)
Usage temperature	From -10°C to 40°C
Electrical insulation	Class II
Weight	435 g
Protection rating	IP40 – IK08
Power input (charging)	fast 12 W
	maintenance < 2 W
Nominal current	fast 2 A
	maintenance 100 mA
Charging control	1 x green LED
	1 x LED bicolour
Housing material	Technical polymer black
Applicable legislation	CE Marking (93/68/CEE):
	2014/35/EU
	2014/30/EU
	2011/65/EU

---

**Charging times**

---

Ni-MH battery 4,5 Ah	2,5 h
Ni-MH battery 9,5 Ah	5 h

---

**Charging signalling**

---

LED left:	
Green	Connected to the mains
LED right:	
Amber	Torch is charging fast
Red	Maintenance charging of the torch

---

DATA SHEET. Model: C-34Q    \_ Rev. 00 (enero 2021)



**LUZNOR Desarrollos Electrónicos, S.L.**  
Paduleta, 47 · 01015 · Vitoria-Gasteiz · 945 200 961  
NIF: B01266451 · luznor@luznor.com · www.luznor.com



## Dimensions

---

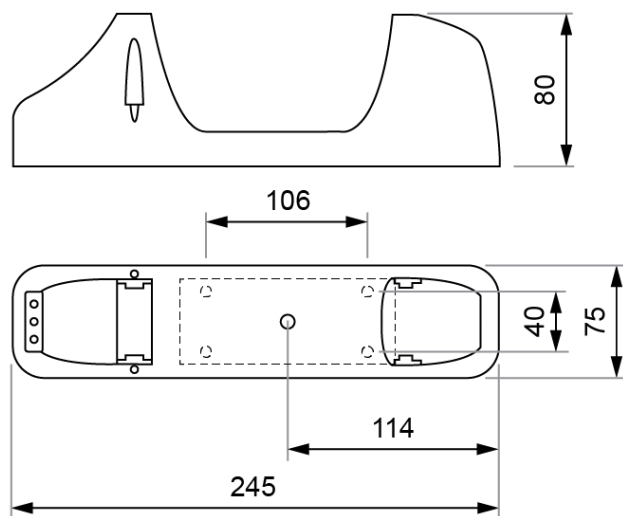

---

DATA SHEET. Model: C-34Q \_ Rev. 00 (enero 2021)



LUZNOR Desarrollos Electrónicos, S.L.  
Paduleta, 47 · 01015 · Vitoria-Gasteiz · 945 200 961  
NIF: B01266451 · luznor@luznor.com · www.luznor.com

