

---

**DATA SHEET. Model: C-73Q.**

---

Individual charger for torches of the QS Series.



---

**Description**

---

Individual charger to optimally charge any type of torch from the QS Series.  
Fast charging by means of three leads that provide steadily current without electrical hazard.  
Durable design that ensures a strong fastening of the torch in accordance with the aesthetics.  
Mounting of the charger on any surface through a metallic fixation plate with four screws.

---

**Technical characteristics**

---

Power supply	230 VAC – 50 Hz
Plug type	European (C, E, F)
Usage temperature	From -10°C to 40°C
Electrical insulation	Class II
Weight	435 g
Protection rating	IP40 – IK08
Charging time	Li-Ion 2,6 Ah    5 h
Power input (charging)	fast                    12 W
	maintenance       < 2 W
Intensidad de carga	fast                    500 mA
	maintenance       50 mA
Charging control	1 x LED green
	1 x LED bicolour
Housing material	Black technical polymer
Applicable legislation	CE marking (93/68/CEE):
	2014/35/EU
	2014/30/EU
	2011/65/EU

---

**Charging signalling**

---

LED left:	
Green	Connected to the mains
LED right:	
Amber	Torch is charging fast
Red	Maintenance charging of the torch

---

**Dimensions**

---

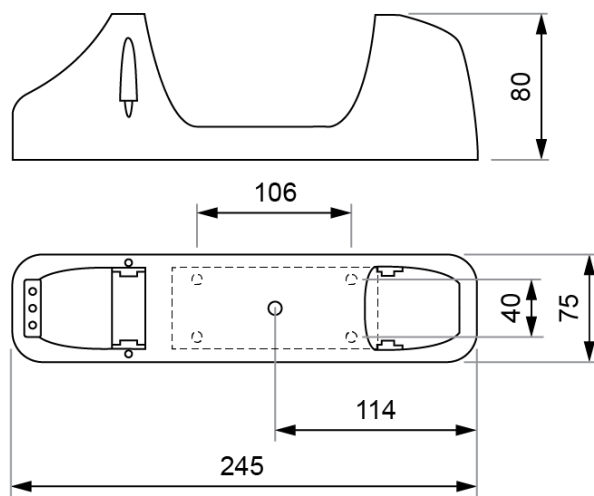

---

DATA SHEET. Model: C-73Q    \_ Rev. 00 (enero 2021)



**LUZNOR Desarrollos Electrónicos, S.L.**  
Paduleta, 47 · 01015 · Vitoria-Gasteiz · 945 200 961  
NIF: B01266451 · luznor@luznor.com · www.luznor.com

