



CBQ Series OPERATING LIGHT EQUIPMENT

Uninterruptible power supply system in alternating current or direct current. Equipment providing AC output voltage in presence of mains and DC output voltage in absence of mains, in both cases 24 V. Other voltages can be established on request.



Possibilities of the standard range

output voltage	A (h)	power (w)
24 Vac or 24 Vdc	1 or 2	300 - 600 - 1,100

It is possible to request other output voltages and powers: the CBQ equipment range is very wide and totally customizable.

- ◇ Equipment consisting of a battery charger, a battery that provides output voltage when a mains failure occurs, a transformer that provides AC output voltage and a contactor that performs the output switch to the transformer or to the battery.
- ◇ The battery is Pb: watertight, maintenance-free and without gas evolution.

Signalling and alarms

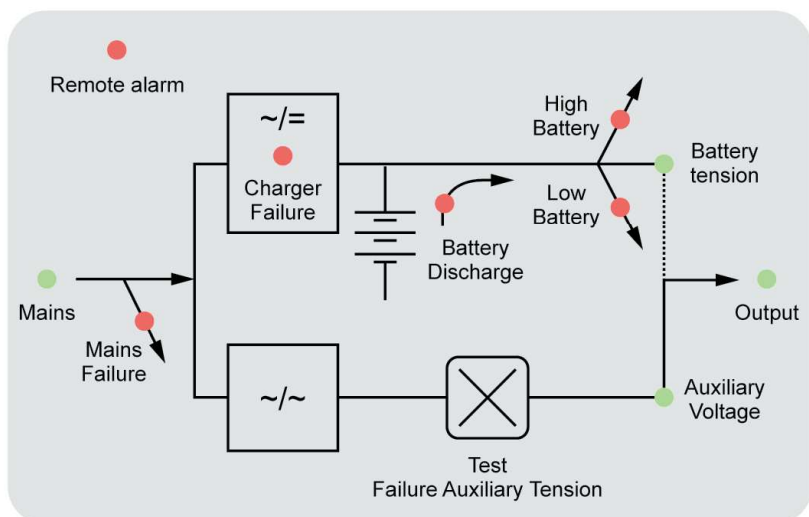

- ◇ It incorporates a synoptical label with LED diodes located on the door, with multiple status signals and alarms.
- ◇ The remote alarm is turned in after a time delay of 10-20 seconds since any alarm occurs. A potential-free inverter contact allows this alarm to be transmitted remotely.